



SLTM
SERIES
GB

UP TO
96
%
A.F.U.E.



HEAT

HIGH EFFICIENCY
CONDENSING BOILERS

LIMITED
LIFETIME
RESIDENTIAL
HEAT EXCHANGER
WARRANTY

5
YEAR
PARTS
WARRANTY



IBC[®]

IBC Control at your fingertips

All SL Series G3 Boilers use our V-10 Touch Screen boiler control which features the latest in advance control technology and software.

Easy to setup and monitor with features like Express Setup, easier Diagnostics & Intuitive Alert System with plain English Warnings & Error Messages, no boiler has ever been easier to use!

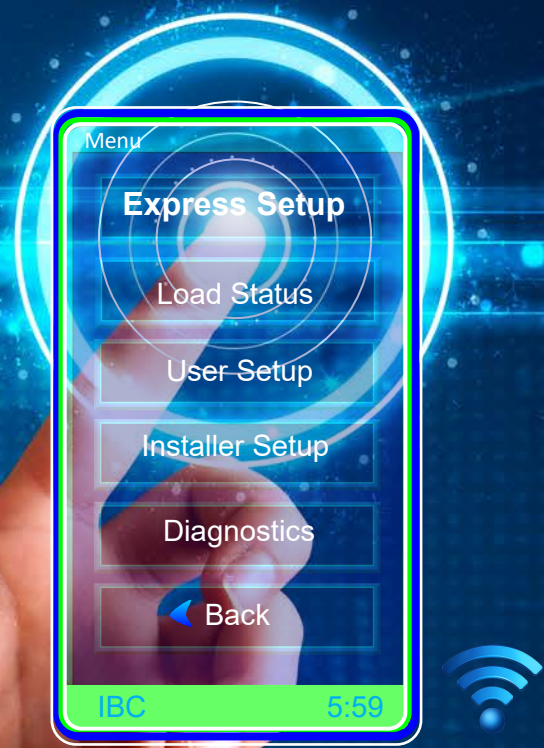

INNOVATION

Interior - Residential Models

- A) Combustion Air
- B) Exhaust
- C) Heat Exchanger
- D) Ignition Module
- E) Fan
- F) Supply Pipe
- G) Return Pipe
- H) Gas valve
- I) Supply Temp. Sensor
- J) Return Temp. Sensor
- K) V-10 Touch Screen
- L) Air Intake Snorkel
- M) Tridicator

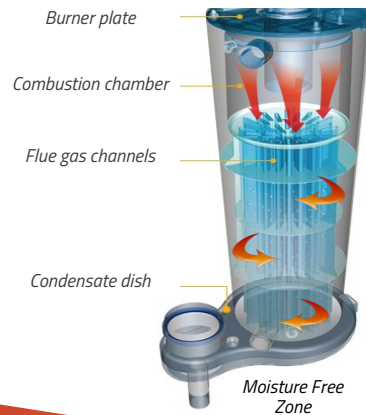

MFZ Technology

MFZ, short for "**Moisture Free Zone**", is IBC's patented moisture management system featured on the SL 115/160/199 260/399.

Residual latent heat can shorten the life of combustion components. Condensate in exchangers can encourage premature wear on the SS surfaces. MFZ eliminates those potential threats at the end of a heating cycle by purging the heat exchanger of moisture and latent heat. This ensures long life for the heat exchanger and all important combustion components.



TOUCH CONTROL

- Express setup - program your boiler in seconds
- Remote monitoring & diagnostics
- Easy USB programmability
- Intuitive alert system with detailed error messages
- Visible flame current data for troubleshooting
- Simplified load pairing
- Optional true native BACnet

EASY TO INSTALL & SERVICE

- With supply and return connection on both sides of 4 models, your boiler installation can't get any easier
- PVC/CPVC/PPs approved
- Longest combined vent lengths – Up to 200 ft in 2" and 480 ft in 3"
- More common parts. With only 2 fans and a universal controller servicing all models just got a lot easier
- Fuel conversion kits included in residential models
- Easy to inspect Heat exchanger featuring a condensate draining system that cleans as it heats

MORE BUILT-IN FEATURES

- Built-in zone pump control - up to 4 zones. Replacing the need for external pump controls
- MFZ Technology: Patented moisture management system. Protects and ensures long life for all components in the boiler
- Turndown ratio of up to 10:1 means you have the power to heat your home in the coldest weather, yet reduce short cycling when the weather is mild

- Reverse flow detection
- Built-in outdoor reset control water temperature.
- Built-in CSA/UL approved low water cut-off and manual reset high limit.
- Unmatched safety features
- Connect your IBC Indirect Water Tank directly to the boiler without a primary loop

SUPERIOR HIGH EFFICIENCY HEAT EXCHANGER

- Efficiency up to 96% A.F.U.E. (SL 399G3 TE/CE 96%)
- One of the most advanced stainless steel fire tube boiler on the market today
- Increased efficiency: Custom baffling to ensure even heat transfer and long life

COMMERCIAL FEATURES

- Multi-boiler communication. Easy boiler network setup. Up to 9.5 million Btu/h (24 boilers) without additional controls
- With 24 boilers turndown ratio is 240:1 = min. firing rate range is 40,000 Btu/h all the way up to 9.5 million Btu/h in 1000 Btu/h increments
- Ti option available on SL 40-399G3
- DDC Control 0-10 VDC or 4-20 mA without additional controls



SL SERIES G3

Residential

Models:

SL 85 G3, SL 115 G3, SL 160 G3

PIPING CONNECTIONS

A. Exhaust Outlet	3" Schedule 40
B. Combustion Air	3" Schedule 40
C. LCD Display	2 1/4" x 4"
D. Water Outlet	1" NPT - M
E. Water inlet	1" NPT - M
F. Knock-outs (8)	1/2"
G. Gas Inlet	1/2" NPT - F
H. Condensate Outlet	3/4" Hose

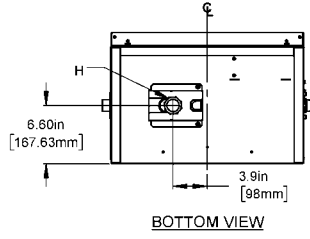
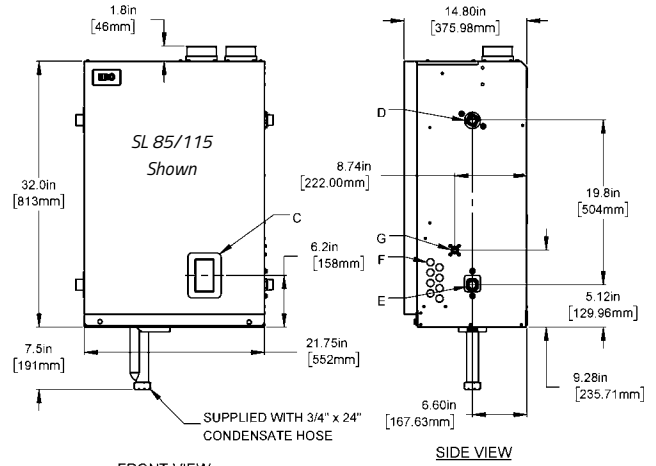
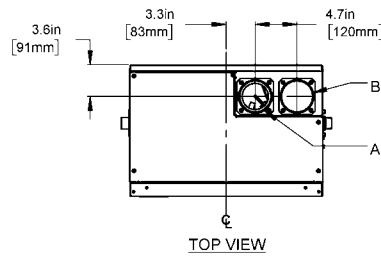

SL 199 G3

PIPING CONNECTIONS

A. Exhaust Outlet	3" Schedule 40
B. Combustion Air	3" Schedule 40
C. LCD Display	2 1/4" x 4"
D. Water Outlet	1 1/4" NPT - M
E. Water inlet	1 1/4" NPT - M
F. Knock-outs (8)	1/2"
G. Gas Inlet	1/2" NPT - F
H. Condensate Outlet	3/4" Hose

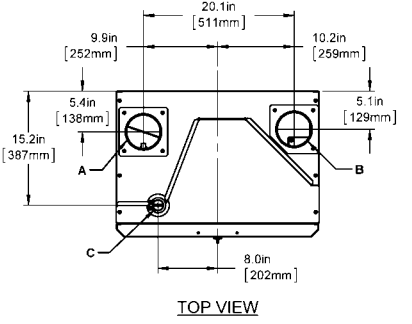
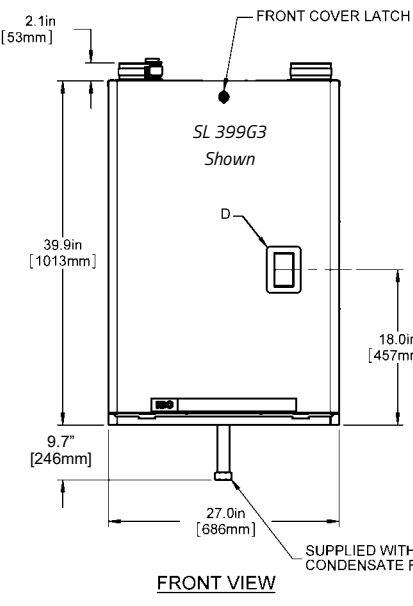

Commercial

Models:

SL 260 G3, SL 399 G3

PIPING CONNECTIONS

A. Exhaust Outlet (260)	3" Schedule 40
A. Exhaust Outlet (399)	4" Schedule 40
B. Combustion Air (260)	3" Schedule 40
B. Combustion Air (399)	4" Schedule 40
C. Relief Valve & Air Vent	3/4" NPT - F
D. Touchscreen Display	2 1/4" x 4"
E. Water Outlet	1 1/2" NPT - M
F. Water inlet	1 1/2" NPT - M
G. Knock-outs (8)	1/2"
H. Gas Inlet	3/4" NPT - F
I. Condensate Outlet	3/4" Hose

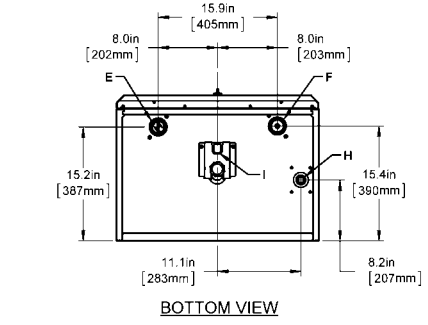
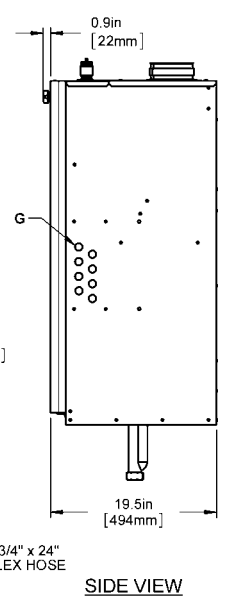

VENTING	MAXIMUM EQUIVALENT LENGTH				
	SL 85G3 / SL 115G3	SL 160G3	SL 199G3	SL 260G3	SL 399G3
Sched.40; Rigid PPs					
2"	100'	35'			
3"	240'	170'	150'	200'	
4"					200'
90° Vent elbow	allow 8' equivalent	allow 8' equivalent	allow 8' equivalent	allow 8' equivalent	allow 8' equivalent
90° Long sweep elbow	allow 5' equivalent	allow 5' equivalent	allow 5' equivalent	allow 5' equivalent	allow 5' equivalent
45° Elbow	allow 3' equivalent	allow 3' equivalent	allow 3' equivalent	allow 3' equivalent	allow 3' equivalent
PPs 87-90° Elbows	use 8' equivalent	use 8' equivalent	use 8' equivalent	use 8' equivalent	use 8' equivalent
2" SS Sidewall Terminal	allow 20' equiv. of 2" sched. 40				
3" SS Sidewall Terminal	allow 20' equiv. of 3" sched. 40	allow 20' equiv. of 3" sched. 40	allow 20' equiv. of 3" sched. 40	allow 20' equiv. of 3" sched. 40	allow 65' equivalent
3" CPVC					for each 1' allow 3.2' equivalent
Flexible PPs					
3" Flexible	45' (max.) lineal x 1.2 = equiv.	45' (max.) lineal x 2 = equiv.	30' (max.) lineal x 3.33 = equiv.	60' (max.) lineal x 3.33 = equiv.	
4" Flexible					160' max, using 1.2 x for equiv. length

CLEARANCE FROM BOILER CABINET	Surface	SL 85G3 / SL 115G3 / SL 160G3 / SL 199G3		SL 260G3		SL 399G3	
		Distance from combustible surfaces	Recommended distance for installation and service	Distance from combustible surfaces	Recommended distance for installation and service	Distance from combustible surfaces	Recommended distance for installation and service
Front		2"	24"	2"	24"	2"	24"
Rear		0"	0"	0"	0"	0"	0"
Left side		1"	4" (to non-combustibles)	1"	4" (to non-combustibles)	1"	0" (to non-combustibles)
Right side		1"	4" (for electric and gas if required)	1"	4" (for electric and gas if required)	1"	4" (for electric and gas if required)
Top		2"	6" (for vent connection)	2"	6" (for vent connection)	12"	12" (for vent connection)
Bottom		0"	12" (for condensate trap and piping)	0"	12" (for condensate trap and piping)	12"	12" (for condensate trap and piping)



**MULTIPLEX
RACKING**

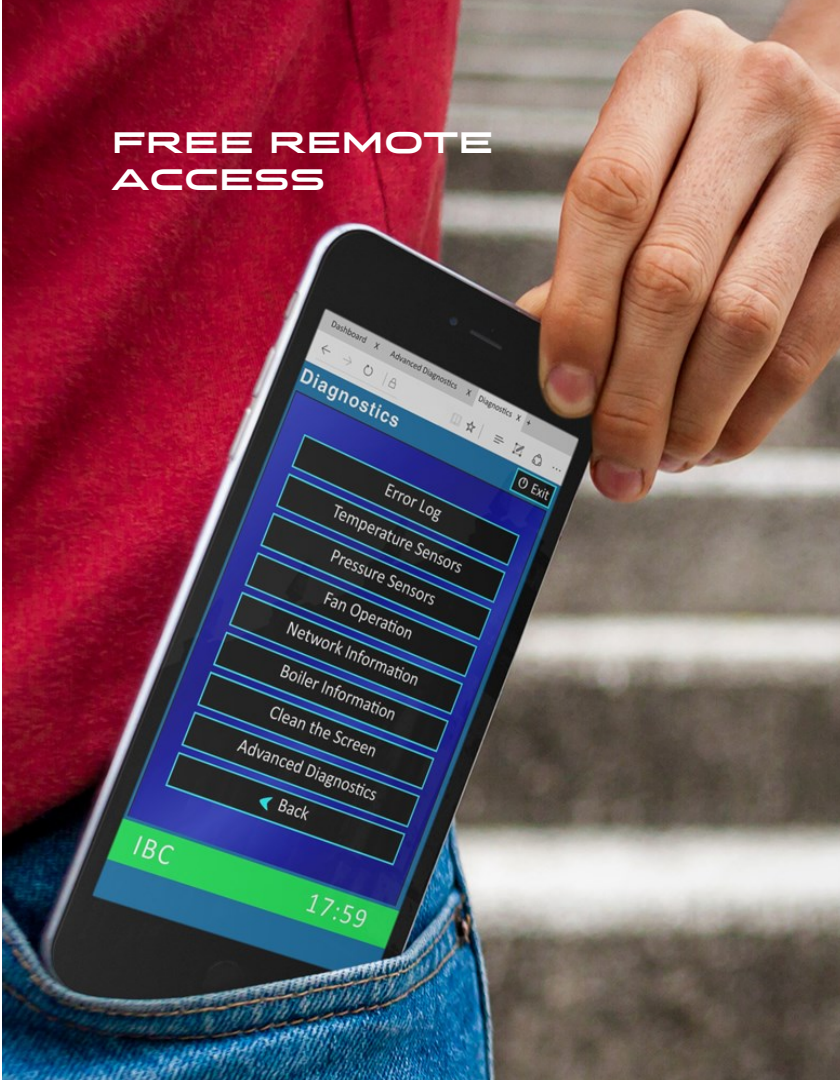

**FREE REMOTE
ACCESS**



SL SERIES G3

Technical Information



Image courtesy of:
Mertz Plumbing & Heating
Inc. (Alberta)

SPECIFICATIONS	SL 85	SL 115	SL 160	SL 199	SL 260	SL 399
CSA Input (Natural Gas or Propane *) - MBH	10.6 - 85	14 - 115	20 - 160	32 - 199	26 - 260	40 - 399
CSA Input (Natural Gas or Propane *) - KW	3.10 - 24.9	4.10 - 33.7	5.86 - 46.7	9.37 - 58.3	7.6 - 76.2	11.7 - 117
CSA Output - MBH	10.1 - 79	13.3 - 109	19.0 - 147	30 - 181.3	24.9 - 239	38.4 - 383
CSA Output - KW	2.96 - 23.1	3.90 - 32	5.57 - 43.1	8.8 - 3.1	7.31 - 70.0	11.2 - 112
A.F.U.E.	96%	95%	95%	95%	95%	96%
Thermal Efficiency						96%
Min gas pressure (NG or Propane) - inch w.c.	4	4	4	4	4	4
Max gas pressure (NG or Propane) - inch w.c.	14	14	14	14	14	14
Ambient temperature - Low (°F/°C)	32°F / 0°C	32°F / 0°C	32°F / 0°C	32°F / 0°C	32°F / 0°C	32°F / 0°C
Ambient temperature - High (°F/°C)	122°F / 50°C	122°F / 50°C	122°F / 50°C	122°F / 50°C	122°F / 50°C	122°F / 50°C
Max relative humidity (non-condensing)	90%	90%	90%	90%	90%	90%
Min water temperature	34°F / 1°C	34°F / 1°C	34°F / 1°C	34°F / 1°C	34°F / 1°C	34°F / 1°C
Max water temperature (electronic hi-limit)	190°F / 88°C	190°F / 88°C	190°F / 88°C	190°F / 88°C	190°F / 88°C	190°F / 88°C
Max ΔT - supply / return (electronic fence)	40°F	40°F	40°F	40°F	40°F	40°F
Max water temperature (lockout limit)	201°F / 94°C	201°F / 94°C	201°F / 94°C	201°F / 94°C	201°F / 94°C	201°F / 94°C
Power use (120Vac/60Hz) - Watts @ full fire - Watt (less pumps)	54	72	82	100	127	190
Weight (empty) - lbs/Kg	85 / 39	85 / 39	102 / 46.3	152 / 69	162 / 74	240 / 110
Pressure vessel water content - USG/Liters	2.47 / 9.35	2.47 / 9.35	1.72 / 6.51	5.09 / 19.3	4.64 / 17.6	6.66 / 25.2
Max boiler flow rate - USgpm	14	14	19	25	25	45
Min boiler flow rate - USgpm	2	2	4	6	6	20
Max operating pressure - psig	30	30	30	30	30	80
Min water pressure - psig	8	8	8	8	8	8
Approved installation altitude - ASL	0 - 12,000'	0 - 12,000'	0 - 12,000'	0 - 12,000'	0 - 12,000'	0 - 12,000'
Maximum equivalent vent length, each side (Natural Gas or Propane)	2" 100'	100'	35'	-	-	-
Air intake options: either direct vent or indoor supply	3" 240'	240'	170'	150'	200'	-
	4"					200'

Accessories



Floor Stands



Multiplex Racking



Piping Kit



Condensate Tank



Parts Kit



Vents Kits



We are committed to delivering a *GREATER DEGREE OF GOOD* across the globe, through our intelligent products, responsible processes and inspired people.

IBC Technologies

sales@ibcboiler.com ■ www.ibcboiler.com

Toll Free: 1-844-HEAT IBC / 1-844-432-8422

IBC®

All information contained in this brochure is subject to change without notice. Due to clerical error, regulation change or product development please confirm all information with IBC INTERGAS

900-041 (R8)